

# SPECIAL REPORT: HEALTH & MEDICAL

**PSD**

EUROPE

Power Systems Design: Empowering Global Innovation

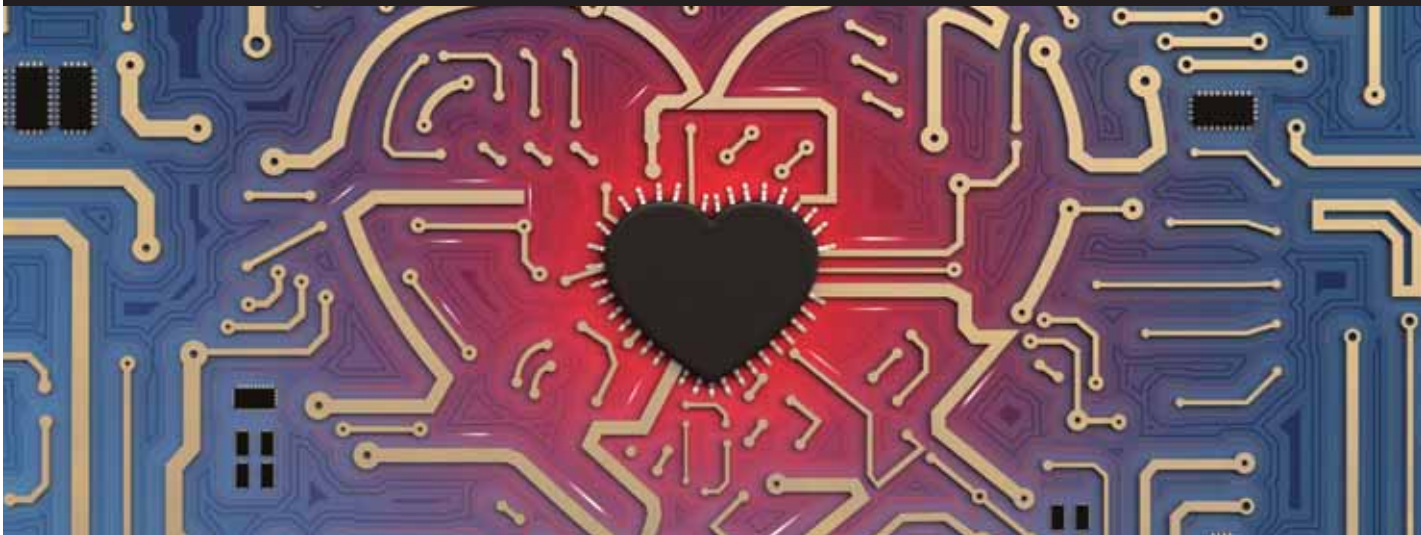

## INSIDE:

---

SMART BATTERY MANAGEMENT...

46

POWERING MEDICAL...

50

LOWEST COST MEDICAL...

54

PORTABLE ULTRASOUND...

58

MEDICAL EQUIPMENT DESIGN...

62

# SMART BATTERY MANAGEMENT IN MEDICAL DEVICES

Provides accuracy, ease-of-use and reliability

By Shadi Hawawini and George Paparrizos

Technology advancements over the past few years have generated many new developments that have specifically benefitted the portable medical device market. The focus of such efforts has centered on simplifying data collection/logging and reporting; developing products that allow patients to be monitored remotely; and centralizing patient databases for better and faster healthcare delivery.

New portable medical equipment take advantage of the wide adoption of electronic and passive components, materials and software utilized in consumer gadgets, by including features that demonstrate improved reliability, lower cost and faster market entry. As with many other aspects of the medical field, such system designs have their own idiosyncrasies that need to be addressed. Medical devices need to meet certain, stricter criteria for successful market introduction. These include measurement accuracy, product safety, fast charging, longer usable life, and user- and environmental-friendliness.

Measurement accuracy is a requirement for ensuring higher accuracy in the sensing portion of the medical device. In most

cases, this translates to a need for keeping the medical equipment case temperature within certain tolerances. Higher temperature levels have a negative impact on the sensing precision and may require expensive methods

for compensating for potential measurement errors. This is the main driver behind the need for high-efficiency battery charging in such system designs. The graph below demonstrates the power dissipation and temperature levels

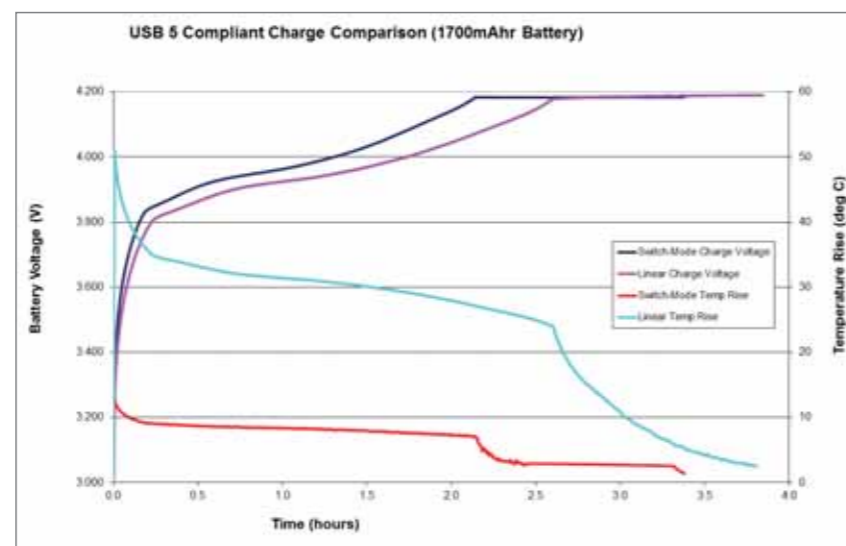

Figure 1: Power dissipation and temperature rise comparison between a linear and a switch-mode battery charging solution

between a switch-mode and a traditional battery charging solution, while charging a 1700mAh battery.

The power dissipation in a linear mode battery charger can be significantly higher, than in a switch-mode battery charge, particularly in cases where the battery voltage is low and the charge current levels are high. The power dissipated for each battery charger type can also be calculated from the below equations. For a switch mode charger, the efficiency will be between 85% and 90%.

$$P_{Diss,Linear} = I_{BQ}(V_{in} - V_{batt})$$

Equation 1: Power dissipation in a linear battery charger (I<sub>BQ</sub> = Battery Charge Current)

$$P_{Diss,Buck} = V_{batt} I_{BQ} \left( \frac{1}{\eta} - 1 \right)$$

Equation 2: Power dissipation in a buck switch-mode regulator

High-efficiency charging can also significantly increase system reliability, since it reduces average ambient temperature levels, which in turn extend the life of other key components and of the portable device itself. Extending usable battery can also be accomplished by reducing frequent and unnecessary charge cycles when the battery voltage is above certain operational levels. Such functionality already exists in some of the modern battery charging solutions on the market and is utilized in other markets where battery charging initiation may be a frequent activity.

Product safety is also a very important factor given that many of the portable medical equipment are used by consumers in a variety of environmental conditions.

Charging Status		IRQ and Current Status	
	Description	IRQ	Current
<input type="radio"/>	Charging is enabled	<input type="radio"/>	<input type="radio"/>
<input type="radio"/>	No charging	<input type="radio"/>	<input type="radio"/>
<input type="radio"/>	Pre charging	<input type="radio"/>	<input type="radio"/>
<input type="radio"/>	Fast charging	<input type="radio"/>	<input type="radio"/>
<input type="radio"/>	Taper charging	<input type="radio"/>	<input type="radio"/>
<input type="radio"/>	At least one charge cycle has occurred and terminated	<input type="radio"/>	<input type="radio"/>
<b>Other Status</b>			
<input type="radio"/>	Battery voltage < 2V	<input type="radio"/>	<input type="radio"/>
<input type="radio"/>	Charger in hold-off	<input type="radio"/>	<input type="radio"/>
<input type="radio"/>	Input OV	<input type="radio"/>	<input type="radio"/>
<input type="radio"/>	Input UV	<input type="radio"/>	<input type="radio"/>
<input type="radio"/>	AC input current limit function complete	<input type="radio"/>	<input type="radio"/>
AC input current limit = __mA			
<input type="radio"/>	Power OK	<input type="radio"/>	<input type="radio"/>
<input type="radio"/>	Source Detection Complete	<input type="radio"/>	<input type="radio"/>
<input type="radio"/>	AICL Done	<input type="radio"/>	<input type="radio"/>
<input type="radio"/>	Taper Charging	<input type="radio"/>	<input type="radio"/>
<input type="radio"/>	Termination Current Reached	<input type="radio"/>	<input type="radio"/>
<input type="radio"/>	Recharge Battery Threshold	<input type="radio"/>	<input type="radio"/>
<input type="radio"/>	Low Battery Voltage	<input type="radio"/>	<input type="radio"/>
<input type="radio"/>	Pre To Fast Battery Voltage	<input type="radio"/>	<input type="radio"/>
<input type="radio"/>	Battery OV	<input type="radio"/>	<input type="radio"/>
<input type="radio"/>	Battery Missing	<input type="radio"/>	<input type="radio"/>
<input type="radio"/>	Pre-charge Timeout	<input type="radio"/>	<input type="radio"/>
<input type="radio"/>	Charge Timeout	<input type="radio"/>	<input type="radio"/>
<input type="radio"/>	Hot Hard Limit	<input type="radio"/>	<input type="radio"/>
<input type="radio"/>	Hot Soft Limit	<input type="radio"/>	<input type="radio"/>
<input type="radio"/>	Cold Soft Limit	<input type="radio"/>	<input type="radio"/>
<input type="radio"/>	Cold Hard Limit	<input type="radio"/>	<input type="radio"/>
<input type="radio"/>	Charger Error	<input type="radio"/>	<input type="radio"/>
<input type="radio"/>	Internal Temperature Limit	<input type="radio"/>	<input type="radio"/>

Figure 2: Graphic user interface demonstrates real-time monitoring of charging state and key failure sources.

Dynamic adjustment of critical charging and power delivery parameters allows for optimal and safe system operation. Medical equipment can also benefit by real-time monitoring and reporting of charging status and potential charging errors. Such functionality can proactively addresses system failures in a timely manner, which is very critical for patients. The figure below demonstrates an example of a battery charging IC that provides a variety of real-time status and fault information to the system.

The input voltage to a device and its subsequent protection is also one of the top safety concerns with medical devices in the field. Although a USB port or a wall adapter should be very well regulated in terms of voltage, a faulty port or wall/car adapter could potentially output 12V or more. Charging ICs are required to tolerate

such over-voltage conditions, thereby protecting the downstream circuitry and eliminating damage to the portable equipment. Another important safety feature is battery temperature monitoring. If the temperature in a battery pack gets too hot, whether it is due to overcharging or high ambient temperatures, it can become a very serious safety hazard. In such cases, modern battery charging ICs can adjust charging voltage or current levels, and in extreme conditions even suspend charging to ensure battery and system health.

Faster charging is another key requirement for modern medical devices, since it allows quick deployment for critical and timely patient monitoring. This is another benefit of the switch-mode battery charging architecture, particularly when powered by a current limited

supply like a USB port. For a switch-mode battery charger, charging from an input current limited source, the following equation gives the current that is “multiplied” to charge the battery, due to efficient input-to-output power transfer in stepping down the voltage. Assuming an efficiency of 90%, an input voltage of 5V, an input limited source capable of 500mA, and a battery voltage of 3V, the current that will go to charging the battery will be 750mA.

$$I_{BQ} = \frac{\eta V_{in} I_{in,limited}}{V_{batt}}$$

Equation 3: Calculation of battery charge current using an input limited source

Another major driving factor behind the development of new portable medical devices is the need for user-friendliness. Given that the devices are targeting a highly diverse population in terms of age, education, ethnicity etc., handling and controlling the device needs to be straight-forward. The easiest interface, and the most universally known and recognized is the USB one. The great benefit of USB for a consumer is its familiarity; it can plug into most PCs or wall adapters, and charge their device, while synchronizing or downloading data. The problem then arises for the device manufacturer, who must ensure that the product is robust and interoperable with a high number of USB hosts, hubs, and wall adapters that may vary in quality. While the USB Battery Charging 1.1 specification has tried to standardize charging from a physical USB cable or connector, there are bound to be non-compliant devices that need to be accounted for. Examples may include adapters that are not properly rated in terms of output current drive

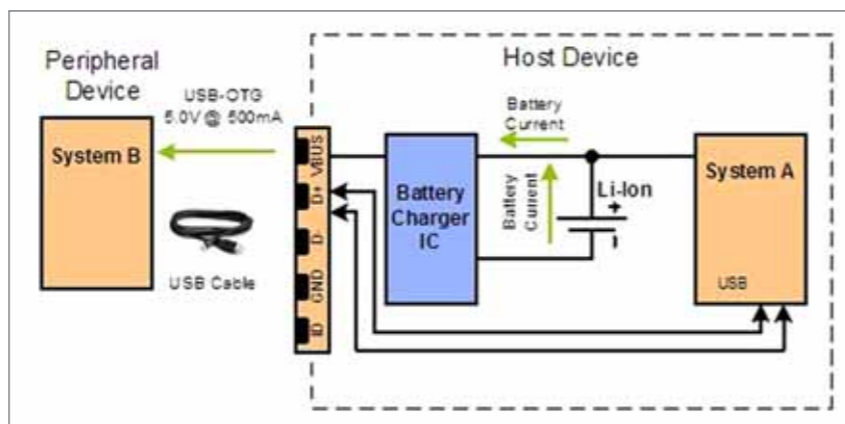

Figure 3: Block diagram demonstrating an innovative battery charging solution that can use the battery as its power source and provide the required power at VBUS for USB on-the-go support.

capability. Clearly if an adapter that can supply 700mA is expected, but the actual adapter can only supply 300mA, then there will be problems with the battery charging resulting in the inability of a patient to charge the device for use. An ideal battery charger should then be able to charge a battery in accordance with the USB Battery Charging 1.1 specification, but should also have the versatility and flexibility to deal with non-compliant peripherals.

Two additional benefits of the adoption of USB as the de-facto interface are: a) the wide industry adoption of micro USB connectors and cables, which guarantees a low-cost solution, and b) the enabling of USB On-the-Go. The latter allows peripheral and master medical devices to connect, communicate with each other and share data without the need of a personal computer. Such an implementation is shown in the below figure.

Environmental trends also have a large impact on new medical electronic designs. The ownership of the equipment requires manufacturers to be responsible for battery replacement and recycling.

The transition to rechargeable battery technologies, such as Li-Ion and Li-Polymer, addresses this issue and eliminates prohibitive cost measures (collecting and recycling old batteries) that may also be shared by patients and the healthcare industry as a whole. These batteries are also manufactured with materials that are environmentally friendlier than their older counterparts.

**Summary**

With an aging patient population and tremendous pressure for cost reductions in the healthcare market, enabling remote medical diagnosis and treatment as well as real-time retrieval of patient data is inevitable. While taking advantage of the popularity, features and environmental friendliness of Lithium-ion battery cells, medical device and equipment makers today must also rely on innovative technology to deliver the most effective charging and power management solutions to meet the market’s stringent requirements.

Author: Shadi Hawawini and George Paparrizos, Summit Microelectronics

[www.summitmicro.com](http://www.summitmicro.com)

# PowerPack Power Systems Design

## Fairchild Semiconductor



**New HVICs Improve Reliability and Performance**

The FAN739x series of high current driving HVIC solutions for motor and industrial applications features an advanced level shift circuit that offers high-side gate driver operation with negative VS swings of up to -9.8V. This new family of HVIC devices improves noise immunity over competitive devices by utilizing an

innovative common-mode dv/dt noise canceling circuit to enable stable operation in high dv/dt noise circumstances. To find more information on Fairchild Semiconductor's new family of HVIC solutions, go to:

[www.fairchildsemi.com](http://www.fairchildsemi.com)

## International Rectifier



**IR's Family of -30 V P-channel Power MOSFETs Offers Design Flexibility and Simplicity**

International Rectifier has introduced a new family of -30 V devices featuring IR's latest P-channel MOSFET silicon in an SO-8 package for battery charge and discharge switches, and system/load switches used in DC applications.

The new P-channel devices offer on-state resistance (RDS(on)) from 4.6 mOhm up to 59 mOhm to match a wide range of power requirements. P-channel MOSFETs eliminate the need for level shifting or charge pump circuitries making them a highly desirable solution for system/load switch applications.

[www.irf.com/whats-new/nr100909.html](http://www.irf.com/whats-new/nr100909.html)

## Infineon



**HybridPACK™ 2 - Compact Power for Your Electric Drive Train.**

Based on the long time experience in the development of IGBT power modules and intense research efforts of new material combinations and assembly technologies, Infineon has developed – dedicated for automotive applications – this HybridPACK™ 2 power module belonging to the HybridPACK™ family. With its pin fin base plate for

direct water cooling Infineon HybridPACK™ 2 is designed to fulfill the requirements of your electric drive train application with power ratings of up to 80kW.

[www.infineon.com/cms/en/product/channel.html?channel=db3a3043136fc1dd011370e812b7043a](http://www.infineon.com/cms/en/product/channel.html?channel=db3a3043136fc1dd011370e812b7043a)

## LEM



This year, LEM will be highlighting a range of products, including the CAS, CASR and CKSR family of current transducers. They are suitable for industrial applications such as variable speed drives, UPS, SMPS, air conditioning, home appliances, solar inverters and also precision systems such as servo drives for wafer production and high-accuracy robots.

LEM is a leading manufacturer of current and voltage transducers used in a broad range of

industrial applications, including variable speed drives for motors and power supplies, AC/DC converters, UPS systems for computers as well as in new innovative energy applications, such as micro-turbines, wind and solar power generation.

For further information please go to

[www.lem.com](http://www.lem.com)

## ITW Paktron



**Non-Polarized Polymer Film Capacitors (CS Series) Designed for Mission Critical Applications**

ITW Paktron's Multilayer Polymer (MLP) Film Capacitors (Type CS Series) feature ultra-low ESR and high ripple current capability and are designed for high frequency filtering and EMI/RFI suppression in power conversion applications. Provides mechanical and electrical stability, compared to multilayer ceramic capacitors.

Features “non-shorting” operation and does not crack like large ceramic chip capacitors under temperature extremes or high vibration. There are no DC or AC voltage coefficient issues with polymer film capacitors.

Capacitance values range from 0.33µF to 20µF and voltage ratings are 50 to 500 VDC. Lead time is stock or four to six weeks.

[www.paktron.com](http://www.paktron.com)

# POWERING MEDICAL APPLICATIONS

## Third edition medical safety standard impacts power supply selection

By Peter Blyth

Safety is paramount wherever power supplies are used, but nowhere more so than in medical applications where even small parasitic leakage currents may compromise safety. First published in 1977, the internationally accepted IEC 60601-1 standard has been continuously developed to help alleviate safety issues relating to all manner of medical equipment.

The latest version is the third edition that was published in December 2005 and that has been adopted on different timescales around the globe. In the European Union, the standard appeared as EN 60601-1:2006 and its three-year transition date expired last September. Similarly, most major countries have adopted IEC 60601-1 as their national standard, in some cases with national variations such as ANSI/AAMI ES60601-1 in the US and Canada's CAN/CSA C22.2 No. 601.1.

Clearly, minimizing risk is a crucial part of any medical equipment design process, and it is in strengthening this aspect that the updates within the third edition focus upon. The standard's range extends to equipment that has a single connection to the ac line supply and that is intended to diagnose,

treat, or monitor patients under medical supervision. Qualifying equipment includes devices that make physical or electrical contact with the patient, and/or transfer energy to or from the patient, and/or detect energy transfer to or from the patient. The most significant change that the third edition introduces is that equipment manufacturers must now follow a formal risk management procedure that follows the ISO 14971 model, which effectively means that you now have to comply with a process standard as well as the fundamental product standard.

While the second edition simply addressed basic safety issues to ensure freedom from any electrical, mechanical, radiation, and thermal hazards, it did not require devices to remain functional—fail-safe was adequate, and compliance with test criteria relied upon a pass/fail result that did not take into account the essential performance of the device-under-test. Recognizing these limitations, the third edition introduces specifications for "essential performance" that requires equipment to continue functioning as its designers intended throughout the test process.

Figure 1: IEC60601-1 third edition demands that two means of protection (MOPs), or isolation barriers exist where patients may come into contact with equipment.

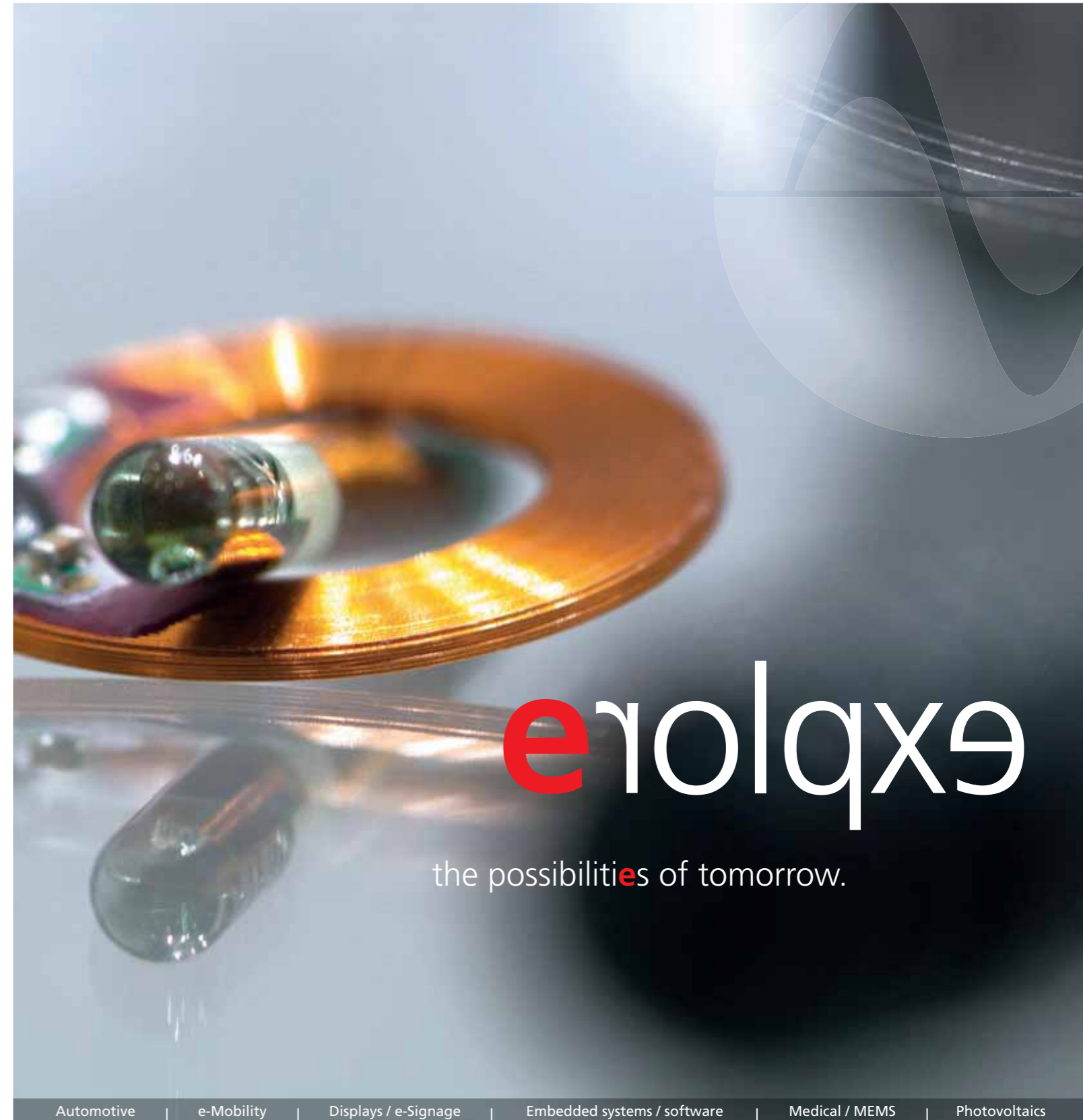
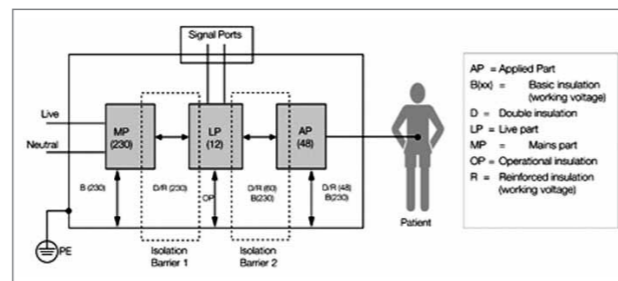

Automotive | e-Mobility | Displays / e-Signage | Embedded systems / software | Medical / MEMS | Photovoltaics

### Time for electronics. Time for the future.

Key topics, trends and technologies. The latest components, systems and applications. Visit [electronica 2010](#), the international trade fair that will show you today what is important tomorrow and generate momentum for real growth.

Parallel event: [hybridica](#). Trade fair for hybrid-component production. [www.hybridica.de](#)

get the whole picture

**electronica 2010**  
components | systems | applications

[www.electronica.de/en](#)

Within the electrical safety arena, the standard continues to require that equipment implements two Means of Protection (MOP) such that if a failure occurs within one area, a second mechanism safeguards the operator and/or the patient against any electric shock hazard. Figure 1 models the insulation diagram that applies to the main circuit blocks in a notional medical device, and shows the two isolation barriers that provide the two Means of Protection that must be present within a device that may come into contact with a patient.

The standard allows for three defensive approaches that may be used in various combinations—safety insulation, protective earth, and protection impedance. So far as insulation is concerned, a change in terminology sees basic insulation allocated a 1 MOP rating while double or reinforced insulation rates as 2 MOPs. It's therefore essential to determine several key factors from the outset of the equipment design process, including its insulation class and whether it will rely upon a protective earth connection. These considerations extend to the "applied part", if present, that is deliberately attached to the patient. Such applied parts are separately classified as to the level of electric shock protection that they provide.

Significantly for power supplies, the third edition distinguishes between protecting the equipment's operator and the patient within its Means of Operator Protection (MOOP) and Means of Patient Protection (MOPP) categories. This distinction can result in quite different safety insulation and isolation requirements for circuits

that operators and patients may come into contact with. Specifically, anything that falls within the remit of operator protection only has to meet the clearance and creepage requirements that IEC/EN 60950 specifies for general-purpose information and technology equipment. By contrast, circuitry that falls within the realm of patient protection must meet the far more exacting requirements that the second edition of IEC 60601-1 introduced. Furthermore, some equipment may include parts that fall under both categories, with risk analysis techniques often being used to determine the respective boundaries.

In this respect, it's arguable that the third edition of IEC 60601-1 defines patient vicinity less well than in its predecessor. While the second edition drew a boundary of 1.5 m around the patient, the latest version employs risk assessment to determine where the patient is and the likelihood of him or her making contact with any part of the medical equipment. If the risk assessment shows that there is negligible likelihood of contact being made, it's theoretically possible to relax the insulation requirements to those of IEC/EN 60950. This also applies to conscious patients, as the standard now differentiates between conscious and unconscious states and makes the implicit assumption that those who are unconscious require a greater degree of protection. That is, in theory at least, the safety requirements for equipment that only comes into contact with conscious patients may be the same as the requirements for operators.

**Selecting suitable power supplies**  
The main attraction of being able

to specify a supply that meets normal IEC/EN 60950 standards is the potential for cost reduction. For instance, a supply that's built to meet IEC/EN 60601-1's far stricter demands to satisfy its Means of Patient Protection category requires significantly larger creepage distances and air clearances that normal commercial-off-the-shelf supplies employ, together with greater levels of dielectric breakdown test voltages. However, any supply that is used within a patient's vicinity still has to meet IEC/EN 60601-1's earth leakage current requirements, which would almost certainly require significant modifications to a normal commercial unit. Such modifications typically include reducing the values of the Y-capacitors that help reduce the earth leakage current but this has a negative effect on the emissions produced by the power supply. As a result, the modified unit is less likely to meet EMC regulations and may require additional internal and/or external filtering. Re-qualifying a modified supply for safety or EMC concerns can then be a costly and time-consuming exercise.

Marketing considerations can play an important part here too. Despite the cost savings that using standard commercial supplies might present, many medical equipment manufacturers still choose to specify IEC/EN 60601-1-approved parts for any product that is likely to come into contact with a patient, as to do otherwise may compromise salability. From a commercial perspective, the manufacturer faces two main choices here—to possibly save money by purchasing IEC/EN 60950-compliant supplies when the risk assessment determines that



*Figure 2: These 100W AC/DC switchers that meet industrial, ITE and medical specifications cost little more than ITE-only approved units*

this is an option, or to go for a cost-effective IEC/EN 60601-1 approved unit. In a parallel development, component technology and design technique improvements now enable power-supply manufacturers to offer units that simultaneously meet industrial, information technology, and medical standards, with volume manufacturing lowering costs to make medical-quality supplies cost-competitive with commercial units.

For instance, a typical 60W medically-qualified power supply costs around \$35 in quantities of a few hundred pieces. Substituting a normal IEC/EN 60950-compliant part is unlikely to save more than \$5, while at the same time limiting application flexibility. Worse, if you then have to modify the commercial-quality supply to meet say leakage current requirements, this choice is no longer lower cost. It may also limit your market, compromise your brand, or introduce additional and avoidable risks. As a result, specifying IEC/EN 60601-1 approved units that comply with Means Of Patient Protection (MOPP) is becoming a preferred approach for device manufacturers.

Whilst the 3rd edition appears to offer the device manufacturer more

options on the choice of power supply, the fundamental question of risk vs. cost must be considered; does one opt for a cheaper power supply with lower performance to save a few dollars or go for a higher specification power supply that might cost more but reduces the risk to as low as possible. After all, if you get it wrong in medical device design it could severely delay gaining regulatory approval or worse.

#### **45W power supply with medical and industrial safety approvals**

XP Power has announced what is believed to be the world's smallest open frame 45W AC-DC power supply. Setting a new benchmark at this power level, measuring just 50.7 x 76.2 x 26.7mm (2 x 3 x 1.05 inches), the ECS45 single output power supply is 25% smaller than the current industry standard of 2 x 4 inches.

All models have a no load power of less than 0.3W, helping the end equipment comply with internationally recognized energy efficiency standards. In addition, these convection cooled units are highly efficient, typically 87%, resulting in less waste heat to dissipate. The lower profile ECS25 model provides 25W output within the same footprint. They can provide full power output up to + 50 degrees C without the need for any external fans or forced airflow and operate up to + 70 degrees C with derating.

Both models provide the nominal outputs of +12, +15, + 24 or +48VDC. The ECS45 is also available with a single +5VDC 6A output. They have a wide input voltage range of 80-264VAC and are approved for Class I and Class II applications. The



units meet UL60601-1 / EN60601-1 medical equipment safety standards and UL60950-1 / EN60950-1 standards for IT and industrial equipment. They also comply with the EN55011 / EN55022 level B standard for conducted emissions without the need for additional filtering components. Overvoltage, overload and short-circuit protection features are included as standard across the whole range.

These power supplies suit designers of medical, IT or industrial equipment. Applications can cover a wide variety, such as broadcast equipment, computing and data storage. The medical safety approval makes it suitable for products such as portable medical devices, home healthcare devices and personal drug delivery equipment. Covered versions of each model are also available for Class I installations.

*Peter Blyth,  
Medical Industry Director,  
XP Power*

[www.xppower.com](http://www.xppower.com)

# LOWEST COST MEDICAL AND BEYOND

## Analog's New Blackfin® DSP - Ultra Low Cost, 800 MMACs



Rick Murphy, as reported by Cliff Keys

Analog Devices products and technologies have made a significant contribution in healthcare designs – helping shape the future of diagnostics and monitoring equipment, as well as health and wellness devices. At ADI's Munich launch, Rich Murphy, Business Development Manager for Analog Devices' Processors-DSPs Core Products and Technologies Group, presented the company's new, lowest cost DSP including the vital evaluation kit and emulator which fits a broad range of cost-sensitive applications where performance cannot be compromised.

For over 40 years, Analog Devices has defined innovation and excellence in signal processing technologies. The company's comprehensive portfolio of linear, mixed signal, MEMS and digital processing technologies set industry standards and are backed by comprehensive design tools, applications support, and systems expertise. A true systems approach to functional integration and collaboration with customers has created real differentiation in the marketplace.

for just \$3 (10K quantities). Featuring active power draw as low as 88mW and a tiny 9mm x 9mm

64 lead LFCSP package, the Blackfin BF592 now makes integrating high-performance DSP (digital signal

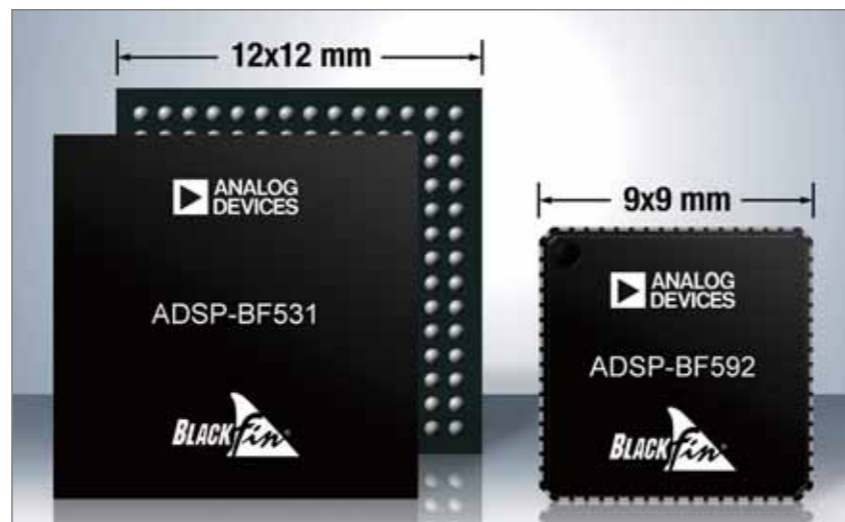

Blackfin ADSP-BF592 DSP with 800 MMACs/400MHz performance

Analog Devices, Inc. introduced the Blackfin ADSP-BF592 DSP with 800 MMACs/400MHz of performance

# Power for Efficiency!



International Exhibition & Conference for  
**POWER ELECTRONICS**  
**INTELLIGENT MOTION**  
**POWER QUALITY**  
 17 – 19 May 2011  
 Exhibition Centre Nuremberg

## Powerful

This is the right place for you!

processing) practical for many power-constrained and small form-factor applications in the industrial, medical, video, audio and general-purpose markets. To download the datasheet, visit the company's website.

Rich explained, "The low-cost, high-performance BF592 opens up many product possibilities for current and new Blackfin customers. Customers can now add very high-performance DSP to products that, due to cost and/or power constrictions, they were unable to before. Having an affordable 800MMACs of DSP allows designers to incorporate sophisticated signal processing previously only feasible for higher-priced end products."

The ADSP-BF592 processor is a member of the Blackfin® family of products, incorporating the Analog Devices/Intel Micro Signal Architecture (MSA). Blackfin processors combine a dual MAC state-of-the-art signal processing engine, the advantages of a clean, orthogonal RISC-like microprocessor instruction set, and single-instruction, multiple-data (SIMD) multimedia capabilities into a single instruction-set architecture.

This processor is completely code compatible with other Blackfin processors and offers performance up to 400MHz and reduced static power consumption.

By integrating a rich set of industry-leading system peripherals and memory, Blackfin processors are the platform of choice for next-generation applications that require RISC-like programmability, multimedia support, and leading-edge signal processing in one

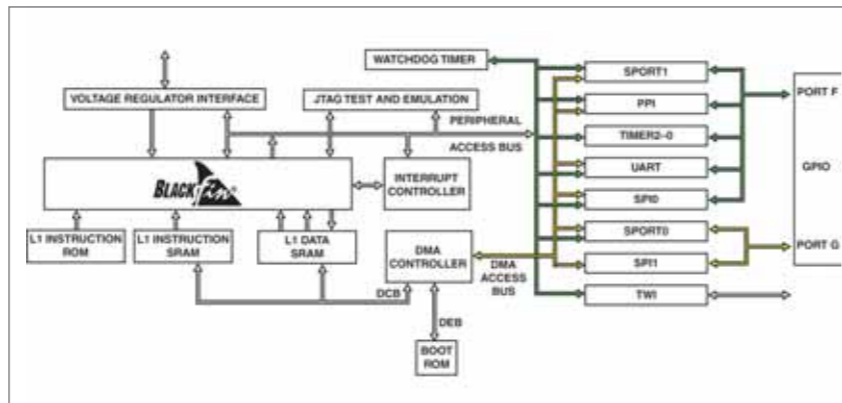

Figure 1: Processor block diagram

integrated package.

#### Portable Low-Power Architecture

Blackfin processors are produced with a low-power and low-voltage design methodology and feature on-chip dynamic power management, which provides the ability to vary both the voltage and frequency of operation to significantly lower overall power consumption. This capability can result in a substantial reduction in power consumption, compared with just varying the frequency of operation. This allows longer battery life for portable appliances.

#### System Integration

The ADSP-BF592 processor is a highly integrated system-on-a-chip solution for the next generation of portable medical, digital communication and consumer multimedia applications. By combining industry-standard interfaces with a high-performance signal processing core, cost-effective applications can be developed quickly, without the need for costly external components. The system peripherals include a watchdog timer; three 32-bit timers/counters with PWM support; two dual-channel, full-duplex synchronous serial ports (SPORTs); two serial peripheral interface (SPI)

compatible ports; one UART® with IrDA support; a parallel peripheral interface (PPI); and a two-wire interface (TWI) controller.

#### Processor Peripherals

The ADSP-BF592 processor contains a rich set of peripherals connected to the core via several high-bandwidth buses, providing flexibility in system configuration as well as excellent overall system performance (see Figure 1). The processor also contains dedicated communication modules and high-speed serial and parallel ports, an interrupt controller for flexible management of interrupts from the on-chip peripherals or external sources, and power management control functions to tailor the performance and power characteristics of the processor and system to many application scenarios.

The SPORTs, SPIs, UART, and PPI peripherals are supported by a flexible DMA structure. There are also separate memory DMA channels dedicated to data transfers between the processor's various memory spaces, including boot ROM. Multiple on-chip buses running at up to 100MHz provide enough bandwidth to keep the processor core running along with activity on all of the on-

chip and external peripherals. The ADSP-BF592 processor includes an interface to an off-chip voltage regulator in support of the processor's dynamic power management capability.

Target applications for the BF592 include portable medical products; audio devices; imaging products, such as CMOS-sensor-based 2D barcode scanners and smart metering products in smart grid applications.

"Analog Devices is pushing the DSP cost/performance envelope to make it easier for designers to differentiate their price- and power-constrained products," said Tony Massimini, chief of technology, Semco Research Corp. "The Blackfin BF592 offers performance and lower power consumption at competitive pricing. These are important factors for designs in high-growth consumer markets, especially portable applications."

#### Blackfin BF592 Highlights

- The highest pure DSP performance for its price point - At 800 MMACs or 400MHz clock speed, the Blackfin BF592 provides developers the ability to run more sophisticated algorithms for more system-level advantages.
- The lowest power in ADI's Blackfin portfolio - The BF592 consumes 80 percent less power than comparable solutions. A low active power draw of just 88mW at 300MHz and low standby power of less than 1mW extends battery life.
- Smaller footprint - With a 9mm x 9mm footprint, the industry's smallest 800MMAC device allows designers to pack a tremendous amount of performance into

space-constrained designs.

- Optimized for multiple applications - With a peripheral set including two SPORTs, a PPI, two SPI's, four general purpose counters and a factory-programmed instruction ROM block containing the VDK RTOS and C-runtime libraries, the BF592 is feature- and cost-optimized for compute-intensive applications that operate without the need for external memory or executable flash.
- The BF592 is offered in commercial and industrial temperature grades and is automotive qualified.

#### Low-cost development platform

An EZ-KIT Lite® evaluation kit for the Blackfin BF592 DSP is available for only \$199, and includes an evaluation suite of ADI's VisualDSP++ development environment with the C/C++ compiler, assembler and linker. ADI also offers a \$150 Blackfin emulator (ADZS-ICE-100B), which provides designers with a comprehensive development platform that lowers the cost of entry to the Blackfin BF592 DSP. In addition, a complementary selection of ADI's power ICs, data converters, sensors, signal conditioning ICs are available for optimizing processor and overall signal chain performance.

#### Innovative Design Demands

##### Blackfin-Class Processing

Analog Devices' Blackfin 16/32-bit processors enable engineers to advance the intelligence, functionality and connectivity of



EZ-KIT Lite® evaluation kit for the Blackfin BF592 DSP

any application that benefits from a convergence of digital signal processing and control processing in a unified architecture. Delivering exceptional price/performance and energy efficiency, and complemented by a rich ecosystem of development tools, applications and third-party support, Blackfin is the processor of choice for a wide range of innovative applications including industrial, medical, automotive, security, digital home entertainment and portable devices.

#### Pricing and Availability

The Blackfin ADSP-BF592 is priced at \$3.00 per unit based on 10,000-unit quantities. The processor is sampling today. EZ-KIT Lite evaluation kits (ADSZ-BF592-EZLITE) for the Blackfin BF592 processor are available now from ADI's authorized distributors and are priced at \$199.

Cliff Keys, Editor-in-Chief, Power Systems Design

Author: Rick Murphy  
Business Development  
Processors-DSPs Core Products  
Analog Devices

[www.analog.com](http://www.analog.com)

# PORTABLE ULTRASOUND SYSTEM DESIGN

Industry's first eight-channel transmit/receive chipset



Suresh Ram as reported by Cliff Key

I had the great pleasure to talk with Suresh Ram, Director, Medical Key Market Segment at National Semiconductor Corporation. Suresh is responsible for driving the strategy and development of innovative system-level solutions targeted at the medical imaging market. He walked me through the company's new medical chipset which enables highest image quality at lowest power, fresh from National's industry-renowned PowerWise portfolio.

National, a leader in power management technology, widely known for its easy-to-use analog ICs and supply chain products, is addressing the needs of the medical design community with products that enable designers in this specialized area to reduce component count and system size and, importantly, to decrease development time and costs. The company's analog portfolio also provides high power efficiency and accuracy, low power and low EMI, enabling medical device designers to achieve significantly better signal path performance and system reliability.

National's launch of the industry's

first eight-channel ultrasound transmit/receive chipset specifically designed for portable ultrasound systems used in hospitals, clinics, ambulances and remote point-of-

care facilities is a milestone in the company's path along the medical route.

Suresh explained that with the

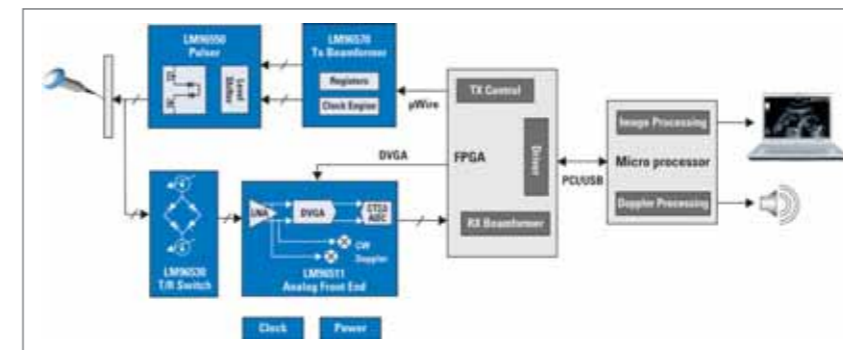

National's comprehensive ultrasound solution

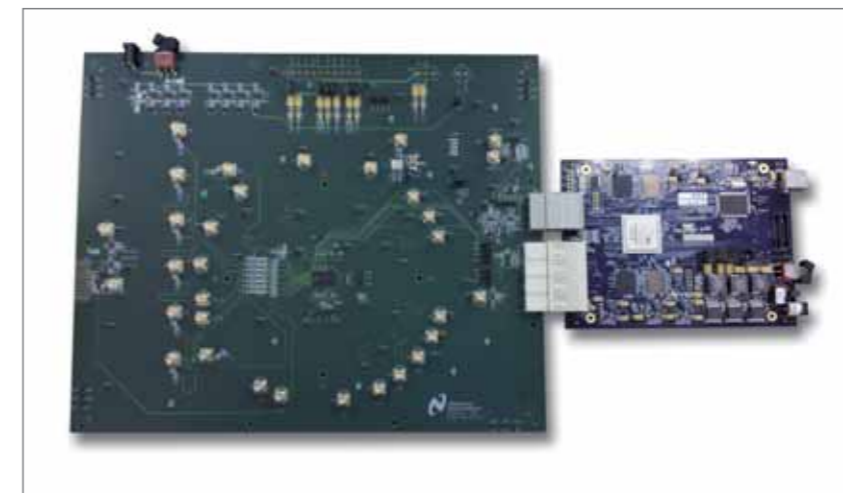

LM96511 AFE Evaluation kit enables detailed chip performance in an easy-to-use format

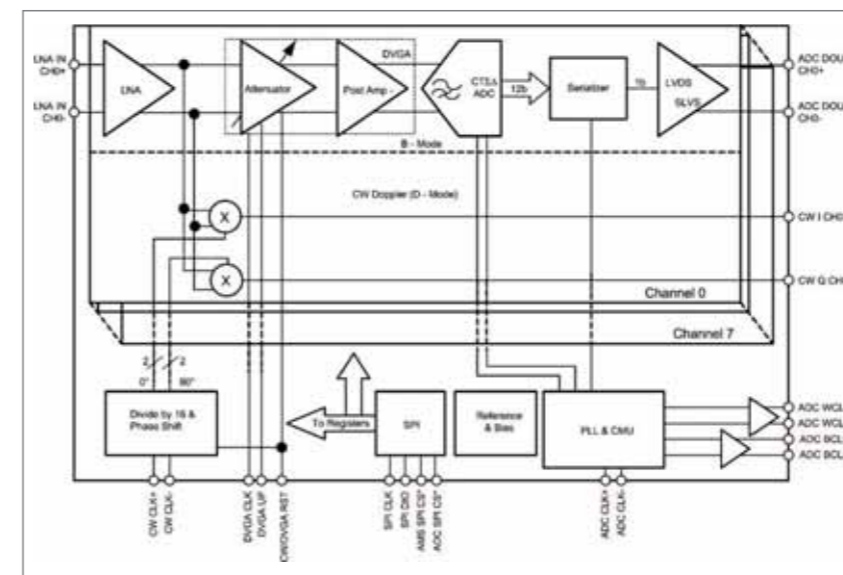

Simplified LM96511 Block Diagram

increasing demand for accessible and affordable medical care, the need for portable diagnostic

imaging equipment is growing. Much of the existing equipment is bulky, extremely expensive,

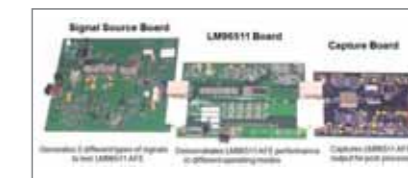

and consumes excessive power. Ultrasound is the least invasive, most mobile imaging technology and with a much lower per scan cost than other options, it is positioned for the fastest growth. National's analog subsystem solutions enable smaller, more efficient portable ultrasound systems for hospitals, clinics, ambulances, and remote point-of-care facilities.

With the industry's first eight-channel transmit/receive chipset designed exclusively for portable ultrasound systems, the company now gives designers the ability to deliver very high diagnostic image quality with low power consumption. The complete chipset includes receive analog front end (AFE), transmit/receive switch, transmit pulser, and configurable transmit beamformer to deliver imaging quality in portable systems that to-date has only been available with significantly larger, cart-based consoles.

The PowerWise® chipset's innovative circuit architecture enables the design of both hand-carried and handheld units that deliver longer battery life and imaging performance which are comparable to much larger console-based systems.

This high-level of integration allows system designers to build lightweight 128-channel portable ultrasound systems with enhanced image quality and diagnostics in a very small footprint.



Dr. Norbert Gaus, chief executive officer of the Clinical Products Division of Siemens Healthcare commented "Previously, this level of ultrasound imaging quality was only attainable with large cart-based consoles. National Semiconductor has significantly raised the bar in terms of imaging performance and low-power consumption for portable ultrasound systems."

National's eight-channel chipset includes four integrated circuits (ICs) that work together to deliver unmatched performance and power efficiency. For example, the transmit beamformer can be configured to calibrate the board trace delay mismatch and pulser delay mismatch. This significantly improves the distortion performance and enables second harmonic imaging. The transmit/receive switch gives system designers the flexibility to trade-off power versus performance by selecting different bias current settings.

National's unique AFE architecture provides superior imaging quality and B-mode power consumption that is 10 percent lower than the closest comparable AFE. It includes the industry's highest resolution digital variable gain amplifier (DVGA) and a low-power continuous-time sigma-delta (CTSD) analog-to-digital converter (ADC). The DVGA offers several advantages over traditional analog VGAs such as better channel-to-channel matching and higher spectral performance. The CTSD ADC provides inherent brickwall anti-aliasing filtering in comparison to higher power consuming, low-order anti-aliasing filters found in other AFEs that use conventional pipeline ADCs.

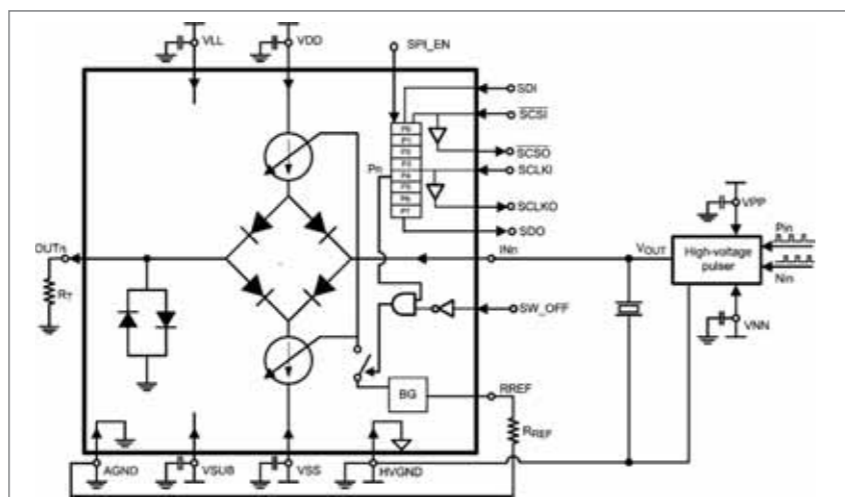

LM96530 Block diagram

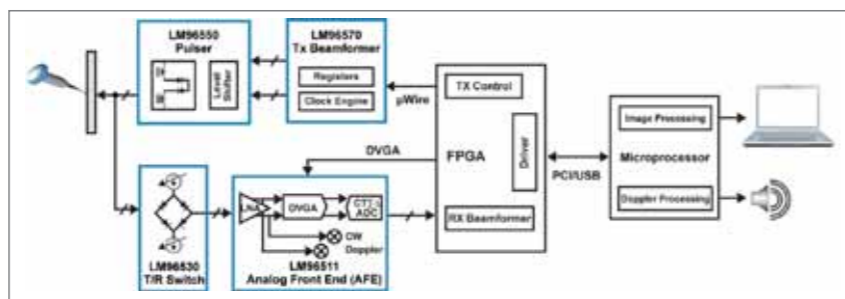

LM96530 Typical application

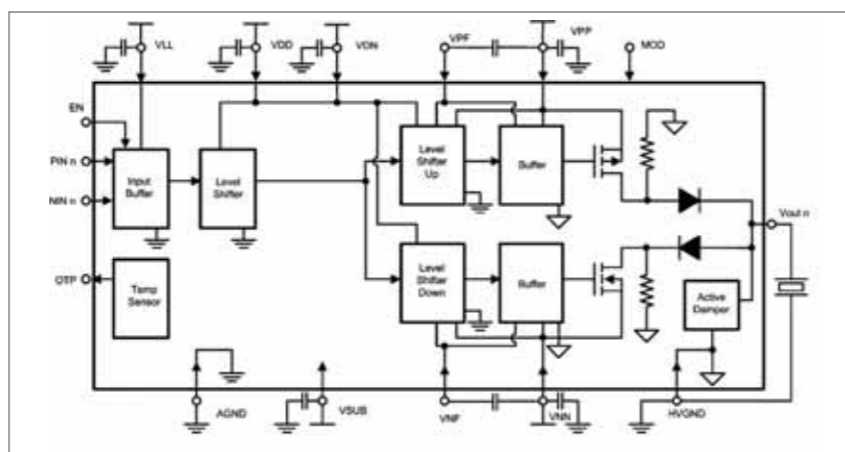

LM96550 Block diagram

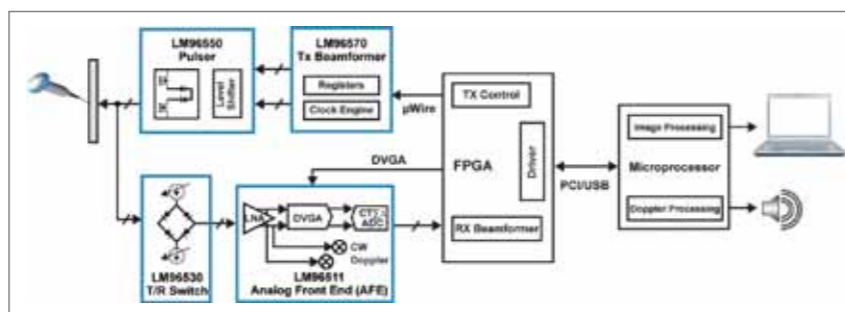

LM96550 Typical application

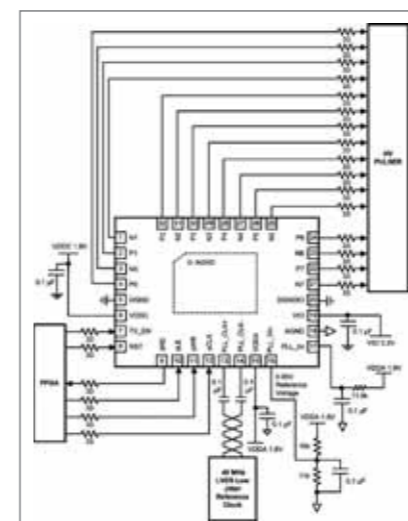

LM96570 Block diagram

National offers a full signal path solution for portable ultrasound systems, including clocking devices and power management ICs. For more information on National's ultrasound transmit/receive chipset and evaluation system (visit [www.national.com/ultrasound](http://www.national.com/ultrasound)). To see a video demonstration of the LM96511 AFE operating in B-mode and CW Doppler-mode, with input signals that emulate a real ultrasound environment visit <http://bit.ly/LM965xxDemoVideo>.

**Development Tools, Support Speed Time-to-Market**

Throughout the whole design process, National's easy-to-use evaluation kits, reference schematics and tools allow fast and accurate evaluation to help designers to accelerate their time-to-market. National offers a full development package that includes the WaveVision 5 acquisition analysis hardware and software with user-friendly GUI for device programming and control.

**LM96511 PowerWise Ultrasound Receive Analog Front End**

The LM96511 AFE integrates eight

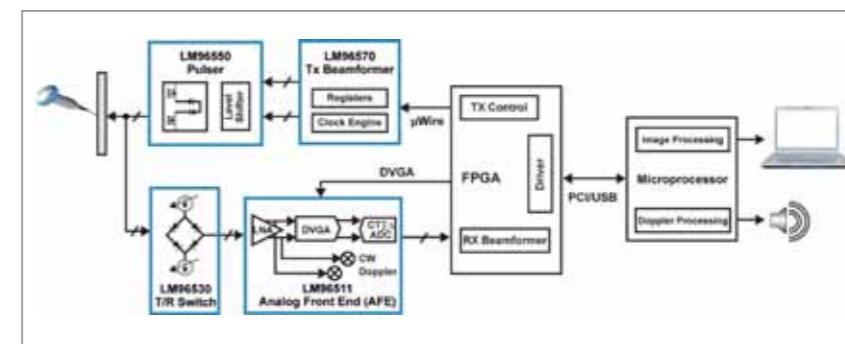

LM96570 Typical application

channels of LNA, DVGA, 12-bit, 40-50 MHz ADC with LVDS data outputs and eight demodulators for CW Doppler beamforming. The AFE provides the lowest B-mode power consumption at 110mW per channel. It enhances image quality with channel-to-channel gain matching of +/- 0.06dB (typical) – and that is four times better than the closest comparable AFE. The integrated CW Doppler delivers 161dB per Hz of dynamic range, enabling measurement of low velocity blood flow in organs such as the liver. The AFE delivers this performance in a 187mm<sup>2</sup> package that's 27 percent smaller than any other comparable AFE.

**LM96530 PowerWise Ultrasound Transmit/Receive Switch**

The LM96530 contains eight transmit/receive switches with integrated clamping diodes and offers an individual channel shut-off capability. Compared to other T/R switches, the LM96530 provides 55 percent better input referred noise (0.5nV/sqrt.Hz) and 53 percent lower on-resistance (16 Ohms), thereby increasing receiver sensitivity and image resolution. The LM96530 reduces board space by 4x compared to discrete solutions, and its daisy-chained SPI control reduces the number of FPGA I/O pins required for programming.

**LM96550 PowerWise Ultrasound Transmit Pulser**

The LM96550 contains eight pulsers with damper circuit that generates +/- 50V bipolar pulses with peak currents up to 2A and pulse rates up to 20MHz. The LM96550 features over-temperature protection by continuously monitoring on-chip temperature and providing power-down logic output.

**LM96570 PowerWise Ultrasound Configurable Transmit Beamformer**

The LM96570 provides an order of magnitude jitter performance improvement (25ps pk-pk) over beamforming traditionally done in FPGAs. This enables much higher resolution imaging in B-mode and low blood velocity measurements in CW Doppler mode. The LM96570 simplifies board layout since system designers can place it directly next to the pulser, thereby avoiding the typical routing challenges of connecting an FPGA's I/O pins to the pulser.

Author: Suresh Ram  
 Director, Medical Key Market Segment  
 National Semiconductor Corporation

[www.national.com](http://www.national.com)

# MEDICAL EQUIPMENT DESIGN

## Operation and design considerations for a digital stethoscope

By John Di Cristina

A stethoscope, whether acoustic or digital, is used mainly to listen to heart and lung sounds in the body as an aid to diagnosis. Listening, or auscultation, has been done with acoustic stethoscopes for almost two hundred years, but recently electronic digital stethoscopes have been developed and adopted.

The goal of a basic digital stethoscope is to have it retain the look and feel of an acoustic stethoscope but to improve listening performance. In addition, high-end digital stethoscopes offer sophisticated capabilities such as audio recording and playback. They also provide data to visually chart results by connecting to an off-instrument display such as a computer monitor. This advanced functionality increases the physician's diagnostic capability. Maintaining the existing acoustic stethoscope form (i.e., that "look and feel") while improving the performance digitally requires the use of small, low-power solutions.

Power management: Key to long use  
Most digital stethoscopes use either one or two AAA 1.5V primary batteries. This design requires a step-up, or boost, switching regulator to increase the voltage to 3.0V or 5.0V, depending on the circuitry utilized.

If a single 1.5V battery is installed, the switching regulator will probably be on all the time, making low quiescent current a critical factor for long battery life. The longer the battery life, the more convenient the digital stethoscope is to use and the closer the experience will be to an acoustic stethoscope.

When using two 1.5V batteries in series, the switching regulator can be left on all the time or shut down when not in use. If the circuit operates from 3.6V down to 1.8V, then a switching regulator may not be needed. Cost will be reduced and space saved. A low-battery warning is required so that a patient's

*Figure 1:  
In a digital stethoscope, low-power operation is key. High-efficiency switching regulators with low standby power, as well as smart battery/power management are needed to ensure long battery life.*

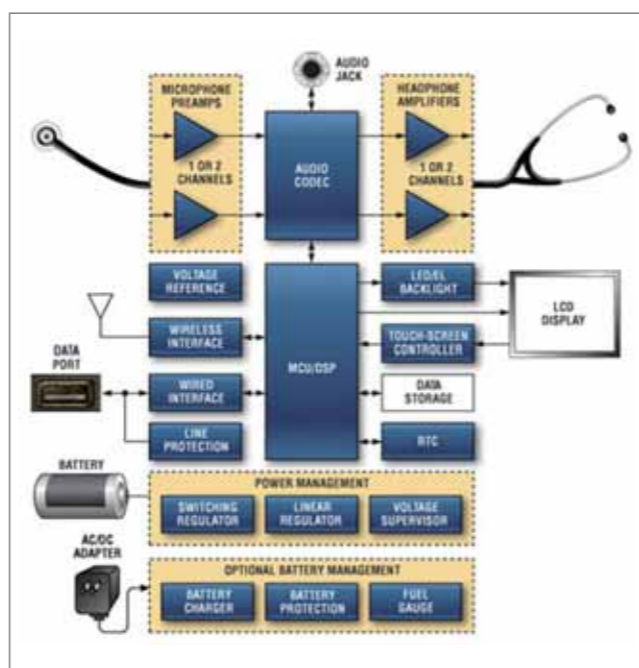

examination need not be interrupted to replace the battery. In the stethoscope, rechargeable batteries can be used; the best choice is a single-cell Li+ battery. If a rechargeable battery is used, a battery charger is required either in the digital stethoscope or in a charging cradle. The charger can be built around a chip such as the MAX8900A or B, or if the battery charger can charge from the USB interface, a device such as the MAX1811 can be used. A fuel gauge such as the MAX17043 or '044 is a good solution to accurately determine the remaining battery life.

If the battery is removable, then battery authentication is also required for safety and aftermarket management. For example, the DS2784 includes a SHA-1 encryption capability for cell authentication. The authentication is used by the stethoscope vendor to prevent counterfeit batteries from damaging the stethoscope.

### Audio signal path

The essential elements of a digital stethoscope are the sound transducer, the audio codec electronics, and the speakers (Figure 1). The sound transducer, which converts sound into an analog voltage, is the most critical piece in the chain. It determines the diagnostic quality of the digital stethoscope and ensures a familiar user experience to those accustomed to acoustic stethoscopes.

The analog voltage needs to be conditioned and then converted into a digital signal using an audio analog-to-digital converter (ADC) or audio codec. Some digital stethoscopes have noise cancellation that requires a

secondary sound transducer or microphone to record the ambient noise so that it can be removed digitally. In this approach, two audio ADCs are required.

Once in the digital domain, a low-power microcontroller such as the MAXQ2000 or MAXQ2010, and/or a digital-signal processor (DSP) performs signal processing, including ambient noise reduction and filtering, to limit the bandwidth to the range for cardiac or pulmonary listening. The processed digital signal is then converted back to analog by a low-power audio digital-to-analog converter (DAC) or audio codec such as the MAX9856 or similar device.

A headphone or speaker amplifier conditions the audio signal before outputting to a speaker. A single speaker can be used below where the stethoscope tube bifurcates, with the amplified sound traveling through the binaural tubes to the ears. Alternatively, two speakers can be used, with one speaker at the end of each earpiece. The frequency response of the speaker is similar to that of a bass speaker because of the low-frequency sound production needed. Depending on the implementation, one or two speaker amplifiers are used.

A stethoscope must be most sensitive to cardiac sound in the 20Hz to 400Hz range and to pulmonary sound in the 100Hz to 1200Hz range. Note that the frequency ranges vary by manufacturer, and the DSP algorithms filter out sound beyond these optimal ranges.

Data storage and transfer  
Once the captured sound is

converted to an analog voltage, it can be sent out through an audio jack and played back on either a computer or through the digital stethoscope. The captured sound can also be manipulated digitally. It can be stored in the stethoscope using internal or removable nonvolatile (NV) memory like EEPROM or flash, and then played back through the stethoscope's speakers; or it can be transferred to a computer for further analysis. Adding a real-time clock (RTC) facilitates tagging the recording with time and date. The captured sound can also be transferred to a host system with a wired interface, such as USB, or with a wireless interface like Bluetooth® or another proprietary wireless interface.

Display and backlighting  
Some digital stethoscopes have a small, simple LCD display due to the limited space available; others have only buttons and LED indicators. Backlighting for the LCD is required because the ambient lighting during medical procedure is often at a low level. The small display requires just one or two white light-emitting diodes (WLEDs) controlled by an LED driver. Alternately, an electroluminescent (EL) panel controlled by an EL driver or other display technology can be used. With the growing popularity of touch-screen technology and the lower associated costs, many of the user-interface buttons can be eliminated by using a touch-screen display and controller.

Author: By John Di Cristina  
Director of Strategic Marketing  
Maxim Integrated Products Inc.

[www.maxim-ic.com](http://www.maxim-ic.com)

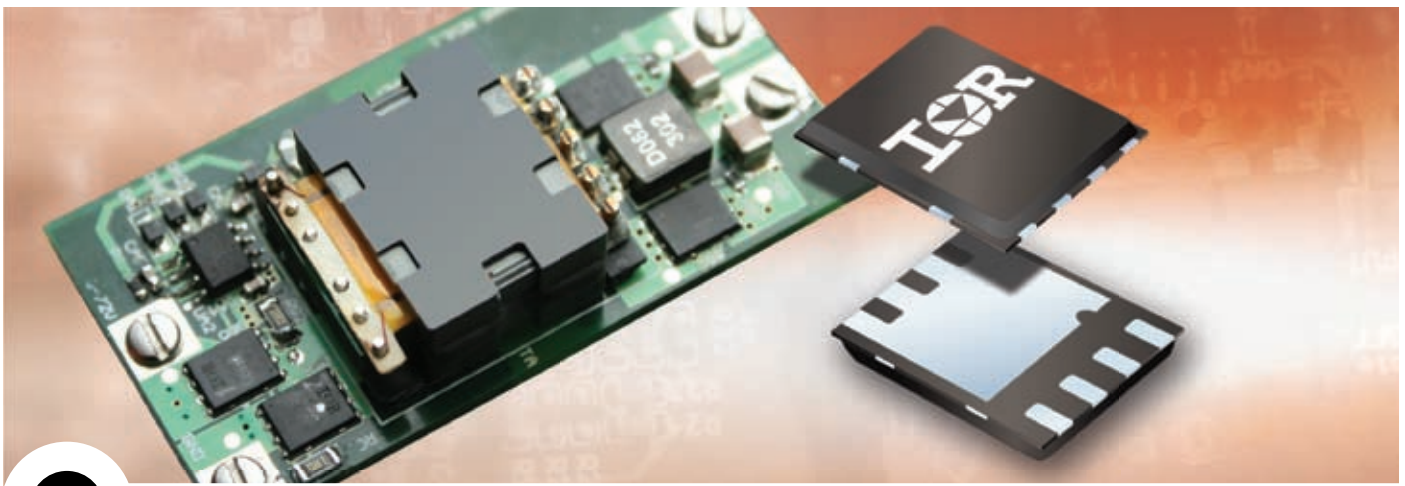

# Introducing 40 V – 250 V MOSFETs in High Current Package

Offering Optimized Performance and Cost for a Given Application

## Standard Gate Drive

Part Number	Package	Voltage	Current	$R_{DS(on)}$ Max. @10V	$Q_g$ Typ @10V
IRFH5004TRPBF	PQFN 5x6mm	40 V	100A	2.6 m $\Omega$	73 nC
IRFH5006TRPBF	PQFN 5x6mm	60 V	100A	4.1 m $\Omega$	67 nC
IRFH5106TRPBF	PQFN 5x6mm	60 V	100A	5.6 m $\Omega$	50 nC
IRFH5206TRPBF	PQFN 5x6mm	60 V	98A	6.7 m $\Omega$	40 nC
IRFH5406TRPBF	PQFN 5x6mm	60 V	40A	14.4 m $\Omega$	23 nC
IRFH5007TRPBF	PQFN 5x6mm	75 V	100A	5.9 m $\Omega$	65 nC
IRFH5207TRPBF	PQFN 5x6mm	75 V	71A	9.6 m $\Omega$	39 nC
IRFH5010TRPBF	PQFN 5x6mm	100 V	100A	9.0 m $\Omega$	65 nC
IRFH5110TRPBF	PQFN 5x6mm	100 V	63A	12.4 m $\Omega$	48 nC
IRFH5210TRPBF	PQFN 5x6mm	100 V	55A	14.9 m $\Omega$	39 nC
IRFH5015TRPBF	PQFN 5x6mm	150 V	56A	31 m $\Omega$	33 nC
IRFH5020TRPBF	PQFN 5x6mm	200 V	41A	59 m $\Omega$	36 nC
IRFH5025TRPBF	PQFN 5x6mm	250 V	32A	100 m $\Omega$	37 nC

## Features

- Low thermal resistance to PCB (down to <0.5°C/W)
- High Current Package – up to 100A continuous
- 100% RG tested
- Low profile (<0.9 mm)
- Industry-standard pinout
- Compatible with existing surface mount techniques
- RoHS compliant containing no lead, no bromide and no halogen
- MSL1, industrial qualification

## The IR Advantage

- Increased power density
- Increased reliability
- Multi-vendor compatibility
- Easier manufacturing
- Environmentally friendlier

## Logic Level Gate Drive

Part Number	Package	Voltage	Current	$R_{DS(on)}$ Max. @4.5V	$Q_g$ Typ @4.5V
IRLH5034TRPBF	PQFN 5x6mm	40 V	100A	2.4 m $\Omega$	43 nC
IRLH5036TRPBF	PQFN 5x6mm	60 V	100A	4.4 m $\Omega$	44 nC
IRLH5030TRPBF	PQFN 5x6mm	100 V	100A	9.0 m $\Omega$	44 nC

For more information call +49 (0) 6102 884 311 or visit us at [www.irf.com](http://www.irf.com)

Visit us in Hall A5, Booth 320



**e**lectronics

New Munich Trade Fair Centre  
09–12 November 2010

International  
**IR** Rectifier  
THE POWER MANAGEMENT LEADER